

Operating Temperature: 0°C~70°C
 Operating Humidity: 20%~80% (no condensation)
 Storage Temperature: -25°C~85°C
 Storage Humidity: 20%~80% (no condensation)

L:
 CBL-43USPD302MBS-3m 3000mm±20mm

No	MATERIALS LIST:
1.	CABLE:UL20276 (1P*30SC#+D+AL+Mylar)*2C+1P*32#+1C*24 OD:4.3mm PVC JACKET COLOR:BLUE
2.	CONNECTOR:USB 3.0 A/M, 9P, BLUE INSULATOR SOLDER TYPE, NICKEL PLATED SHELL
3.	CONNECTOR:USB 3.0 MicroB/M, 10P, BLACK INSULATOR SOLDER TYPE, NICKEL PLATED SHELL
4.	ABS ASSEMBLY HOUSING,BLUE COLOR
5.	SCREW:#3x20.7 M2

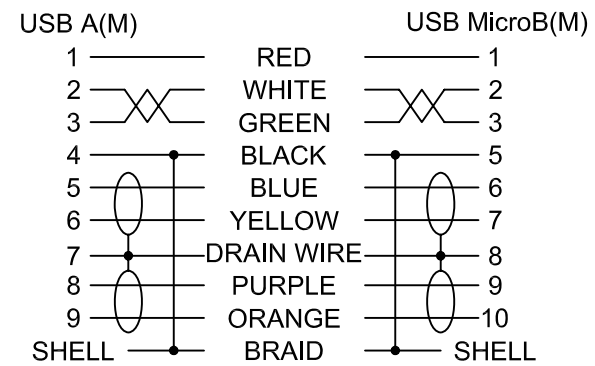

Jargy part no.	Client part no.	Approved	SCALE	UNIT
CBL-43USPD302MBS-Xm				mm
Drawing Name		Drawn	Date	REV.
USB 3.0 A to Micro-B Cable M/M				1.0

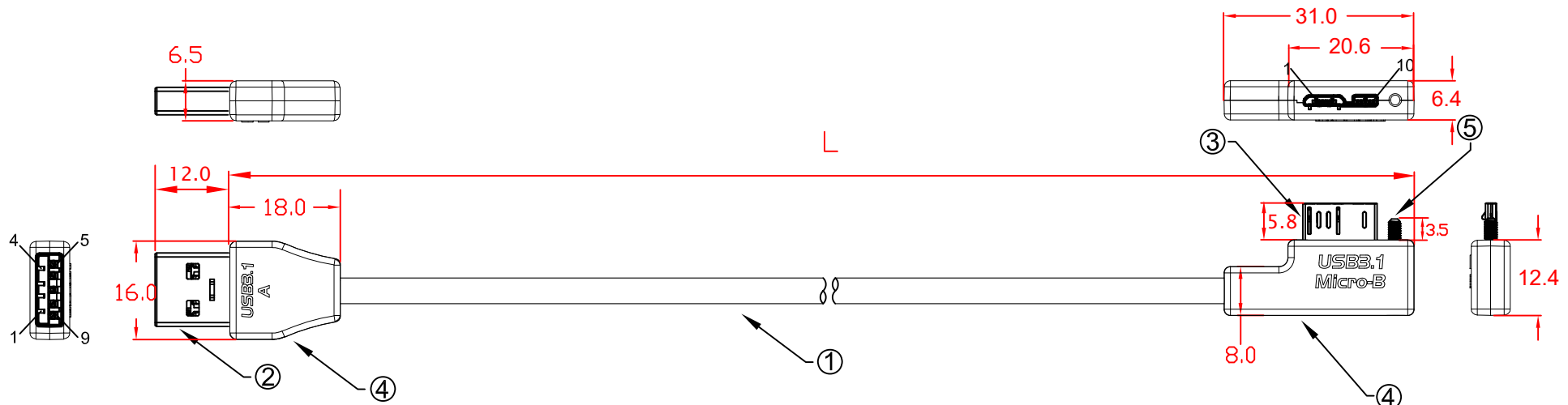

Operating Temperature: 0°C~70°C
 Operating Humidity: 20%~80% (no condensation)
 Storage Temperature: -25°C~85°C
 Storage Humidity: 20%~80% (no condensation)

L:
 CBL-43USPD302MBL-3mLA 3000mm±20mm

No	MATERIALS LIST:
1.	CABLE:UL20276 (1P*30SC#+D+AL+Mylar)*2C+1P*32#+1C*24 OD:4.3mm PVC JACKET COLOR:BLUE
2.	CONNECTOR:USB 3.0 A/M, 9P, BLUE INSULATOR SOLDER TYPE, NICKEL PLATED SHELL
3.	CONNECTOR:USB 3.0 MicroB/M, 10P, BLACK INSULATOR SOLDER TYPE, NICKEL PLATED SHELL
4.	ABS ASSEMBLY HOUSING,BLUE COLOR
5.	SCREW:#3x15.8 M2

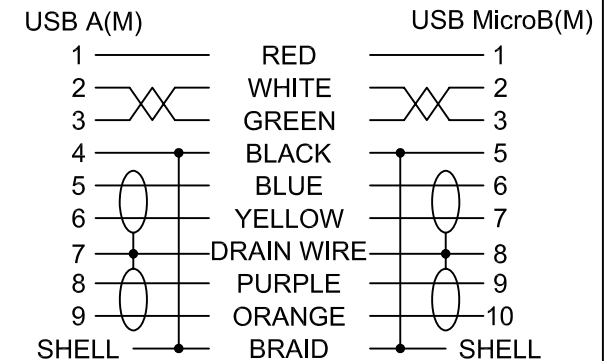

Jargy part no.	Client part no.	Approved	SCALE	UNIT
CBL-43USPD302MBL-XmLA				mm
Drawing Name		Drawn	Date	REV.
USB 3.0 A to Micro-B Cable M/M				1.0

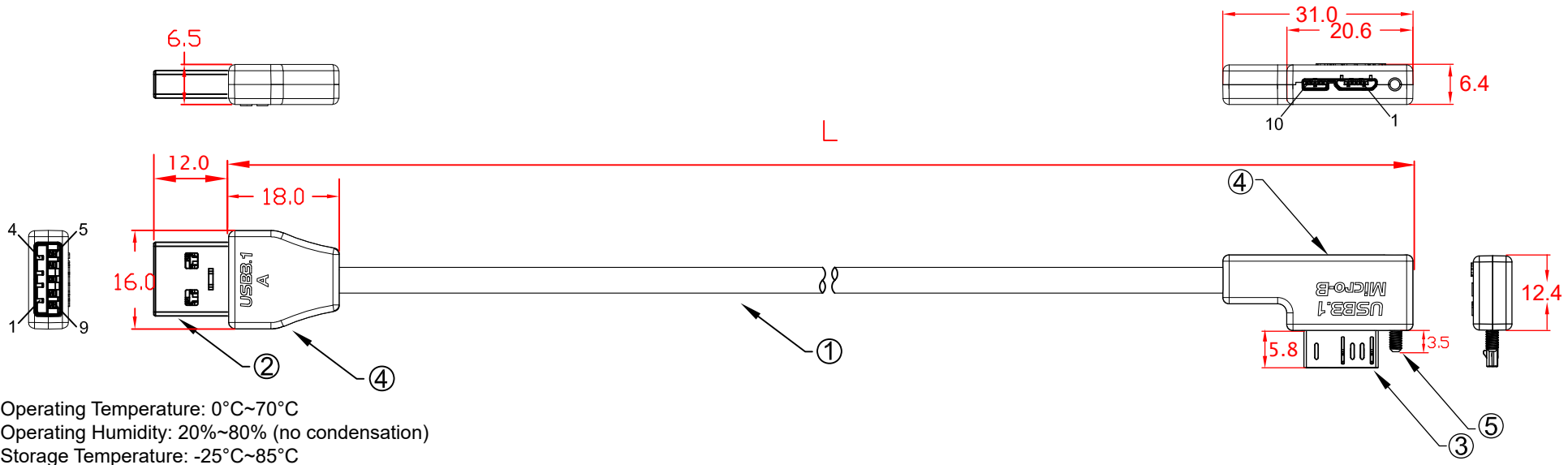

Operating Temperature: 0°C~70°C
 Operating Humidity: 20%~80% (no condensation)
 Storage Temperature: -25°C~85°C
 Storage Humidity: 20%~80% (no condensation)

L:
 CBL-43USPD302MBL-3mRA 3000mm±20mm

No	MATERIALS LIST:
1.	CABLE:UL20276 (1P*30SC#+D+AL+Mylar)*2C+1P*32#+1C*24 OD:4.3mm PVC JACKET COLOR:BLUE
2.	CONNECTOR:USB 3.0 A/M, 9P, BLUE INSULATOR SOLDER TYPE, NICKEL PLATED SHELL
3.	CONNECTOR:USB 3.0 MicroB/M, 10P, BLACK INSULATOR SOLDER TYPE, NICKEL PLATED SHELL
4.	ABS ASSEMBLY HOUSING,BLUE COLOR
5.	SCREW:#3x15.8 M2

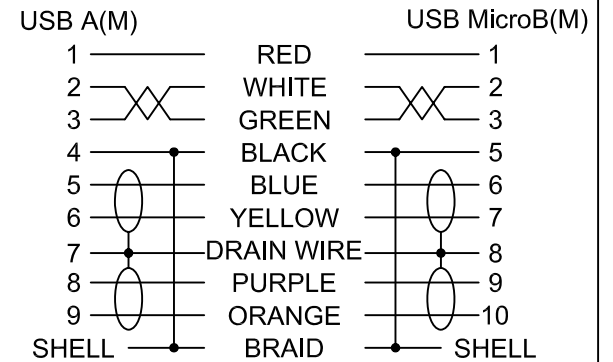

Jargy part no.	Client part no.	Approved	SCALE	UNIT
CBL-43USPD302MBL-XmRA				mm
Drawing Name		Drawn	Date	REV.
USB 3.0 A to Micro-B Cable M/M				1.0

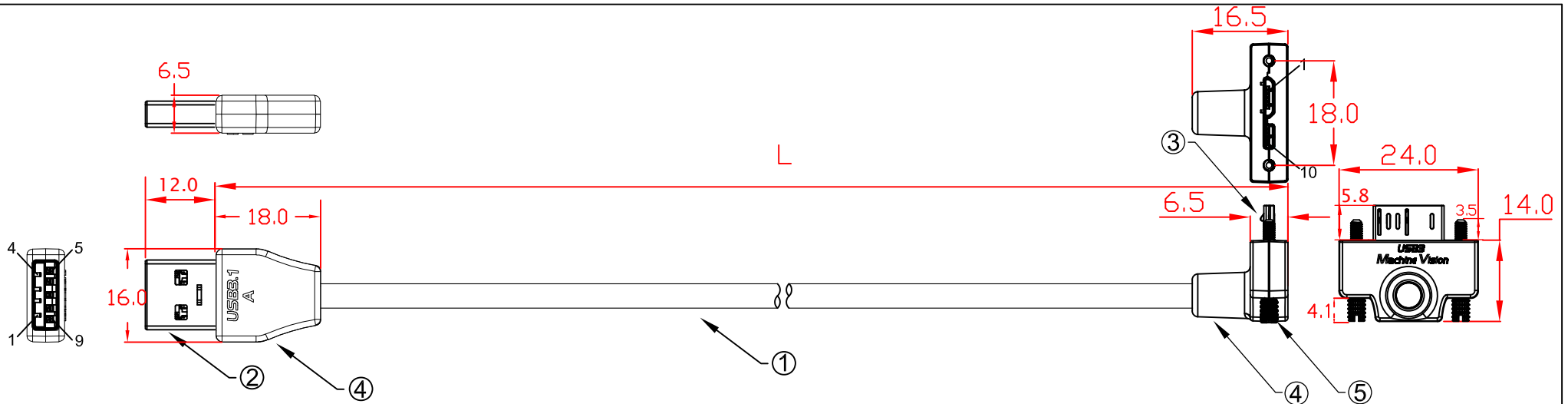

Operating Temperature: 0°C~70°C
 Operating Humidity: 20%~80% (no condensation)
 Storage Temperature: -25°C~85°C
 Storage Humidity: 20%~80% (no condensation)

L:
 CBL-43USPD302MBH-3mUA 3000mm±20mm

No	MATERIALS LIST:
1.	CABLE:UL20276 (1P*30SC#+D+AL+Mylar)*2C+1P*32#+1C*24 OD:4.3mm PVC JACKET COLOR:BLUE
2.	CONNECTOR:USB 3.0 A/M, 9P, BLUE INSULATOR SOLDER TYPE, NICKEL PLATED SHELL
3.	CONNECTOR:USB 3.0 MicroB/M, 10P, BLACK INSULATOR SOLDER TYPE, NICKEL PLATED SHELL
4.	ABS ASSEMBLY HOUSING,BLUE COLOR
5.	SCREW:#3x17.7 M2

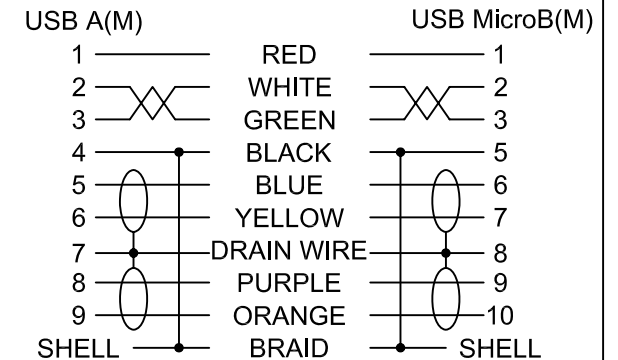

Jargy part no.	Client part no.	Approved	SCALE	UNIT
CBL-43USPD302MBH-XmUA				mm
Drawing Name		Drawn	Date	REV.
USB 3.0 A to Micro-B Cable M/M				1.0

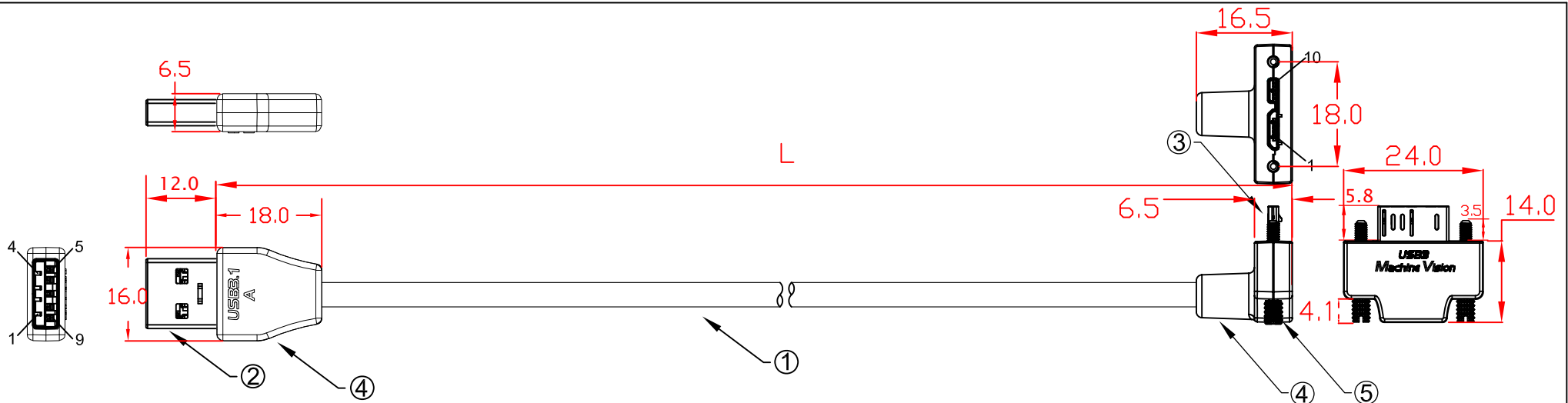

Operating Temperature: 0°C~70°C
 Operating Humidity: 20%~80% (no condensation)
 Storage Temperature: -25°C~85°C
 Storage Humidity: 20%~80% (no condensation)

L:
 CBL-43USPD302MBH-3mDA 3000mm±20mm

No	MATERIALS LIST:
1.	CABLE:UL20276 (1P*30SC#+D+AL+Mylar)*2C+1P*32#+1C*24 OD:4.3mm PVC JACKET COLOR:BLUE
2.	CONNECTOR:USB 3.0 A/M, 9P, BLUE INSULATOR SOLDER TYPE, NICKEL PLATED SHELL
3.	CONNECTOR:USB 3.0 MicroB/M, 10P, BLACK INSULATOR SOLDER TYPE, NICKEL PLATED SHELL
4.	ABS ASSEMBLY HOUSING,BLUE COLOR
5.	SCREW:#3x17.7 M2

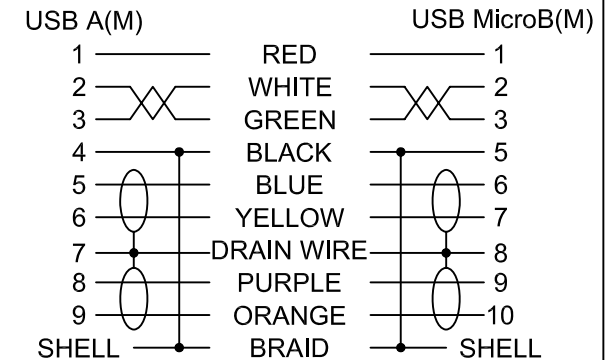

Jargy part no.	Client part no.	Approved	SCALE	UNIT
CBL-43USPD302MBH-XmDA				mm
Drawing Name		Drawn	Date	REV.
USB 3.0 A to Micro-B Cable M/M				1.0